



MOBILE SURGICAL CHAIR

SC 5010 HS / ES



INSTRUCTIONS FOR USE

COPYRIGHT

The distribution and reproduction of this document, and the use or dissemination of its contents are strictly prohibited unless explicitly authorised in writing by the manufacturer. Any infringement of this shall result in payment for damages.

If a patent is granted or a utility model is registered, all rights are reserved.

© AKRUS GmbH

CHANGES TO THE INSTRUCTIONS FOR USE

We reserve the right to make changes in the interests of further technical development; the instructions for use are not subject to revisions.

MANUFACTURER



AKRUS GmbH & Co KG

Otto-Hahn-Straße 3

25337 Elmshorn

Germany

Tel. +49 4121 7919-30

Fax +49 4121 7919-39

Email: info@akrus.de

Website: www.akrus.de



We hereby declare that the device listed herein complies with Machinery Directive 2006/42/EC and the Regulation on medical devices 2017/745/EC.

Users must observe statutory national provisions on accident prevention, Directive 89/391/EEC and Directive 2009/104/EC.



TABLE OF CONTENTS

1. GENERAL INFORMATION	5
1.1. EXCLUSION OF LIABILITY	5
1.2. EXPLANATION OF SYMBOLS USED	5
1.2.1. SAFETY PRECAUTIONS	5
1.2.2. OTHER INFORMATION	5
1.3. SYMBOLS USED	6
2. REPORTING INCIDENTS	8
3. REQUIREMENTS FOR SAFE OPERATION	8
4. PRODUCT SERVICE LIFE AND WARRANTY CONDITIONS	10
5. CONTENTS AT DELIVERY	10
6. INTENDED USE	10
6.1. INTENDED PURPOSE AND INDICATIONS	10
6.2. CONTRAINDICATIONS AND ADVERSE EFFECTS	11
7. PUTTING INTO SERVICE	11
8. ELECTRICAL CONNECTIONS	12
9. ACCESSORIES	12
10. DEVICE DESCRIPTION AND OPERATING CONTROLS	14
10.1. KEYPAD CONTROLS (101-152)	14
10.2. BATTERY (100-925)	14
10.3. BATTERY CHARGING STATION (100-924)	15
10.4. BATTERY HOLDER ON THE SB 5010 HS / ES SURGICAL CHAIR	16
10.5. ELECTRIC DRIVES AND CONTROL UNIT	16
10.6. OPERATING CONTROLS - FOOT-CONTROLLED SWITCH (275.012400 OPTIONAL)	16
10.7. OPERATING CONTROLS - FOOT JOYSTICK (649.012020 OPTIONAL)	17
10.8. WHEEL BASE LEVER	18
11. OPERATING THE SURGICAL CHAIR	19
11.1. CONTINUOUS OPERATION OF THE MOTORS	19
11.2. AUDIBLE SIGNAL, BATTERY CHARGE STATUS	19
11.3. POWER BUTTON (ON/OFF BUTTON)	19
11.4. ELECTRICAL ADJUSTMENT OPTIONS	19
11.4.1. <i>Adjusting the height</i>	19
11.4.2. <i>Backrest adjustment</i>	20
11.4.3. <i>Adjustment of the footrest</i>	20
11.4.4. <i>Adjusting the seat</i>	20
11.4.5. <i>Adjustment of electric head lifter</i>	21
11.4.6. <i>Trendelenburg position</i>	21
11.4.7. <i>Programming the memory buttons (101-152)</i>	22
11.5. ADJUSTING THE HEADREST	23
11.5.1. <i>Adjusting the standard headrest (241.030690)</i>	23
11.5.2. <i>Adjustment of the padded headrest (241.030660)</i>	23
11.5.3. <i>Adjusting the multi-articulated headrest (241.030648)</i>	23
11.5.3.1. <i>Manual adjustment of tilt angle (275.030650)</i>	24
12. DEVICE CARE AND REPROCESSING	25
12.1. GENERAL INFORMATION	25
12.2. REPROCESSING INSTRUCTIONS	26
12.2.1. CLEANING PROCEDURE	26



12.2.2.	DISINFECTION PROCEDURE.....	27
12.2.3.	COMPLETION OF PROCESSING.....	27
13.	CHECKS BEFORE USE.....	28
14.	DEVICE MAINTENANCE AND REPAIR	28
15.	SAFETY INSPECTIONS.....	29
16.	DISPOSAL	29
17.	TECHNICAL DATA.....	31
18.	ENVIRONMENTAL CONDITIONS.....	32
19.	TROUBLESHOOTING	32

1. GENERAL INFORMATION

A thorough understanding of this IFU is essential for use of the SC 5010 HS / ES surgical chair. Please familiarise yourself fully with its contents, paying special attention to all guidance and instructions on how to use the device safely. Keep these instructions for use near the product so that they are accessible to all users.



1.1. EXCLUSION OF LIABILITY

Any improper or unauthorised use or maintenance of the product excludes any liability on the part of the manufacturer.



1.2. EXPLANATION OF SYMBOLS USED

1.2.1. SAFETY PRECAUTIONS

Please take particular care to read and comply with all of the safety precautions and information in the instructions for use.

	CAUTION
	Indicates a potentially hazardous situation. Unless avoided, it may result in minor or moderate injury. May also be used as a warning against unsafe practices or possible damage to the equipment.
	WARNING
	Indicates a potentially hazardous situation. Unless avoided, it may result in death or serious injury.
	HAZARD
	Indicates an imminent hazardous situation. Unless avoided, it will result in death or serious injury.

1.2.2. OTHER INFORMATION

	IMPORTANT
	Indicates possible damage to the product.
	Indicates a required action.

1.3. SYMBOLS USED

The following symbols may be used on products, signs and packaging:

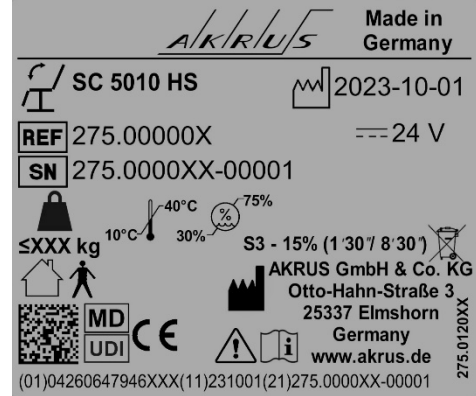
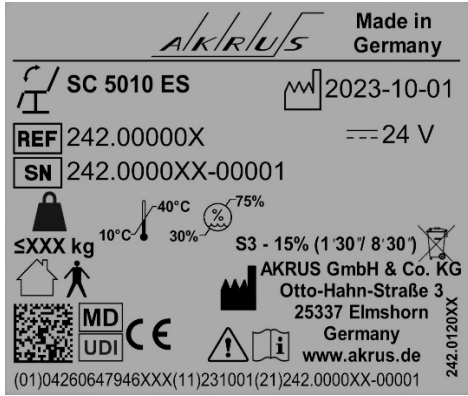



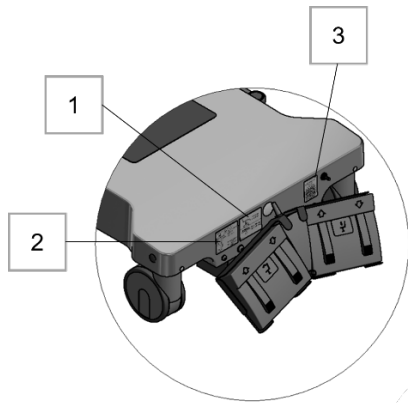





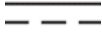

Nameplates













1. Name/rating plates
2. Weight label
3. Service label
4. "Do not sit" prohibition sign
5. "Do not load" prohibition sign

SYMBOL	MEANING
	Manufacturer
	Catalogue number
 [01]04260647946000(11)210301 [21]279.012100-000000	Device identification (data matrix and plain text)
	Indicates the maximum permitted weight the product can support.

SYMBOL	MEANING
	Date of manufacture (YYYY-MM-DD)
	Serial number
	Label identifying the device as a medical device
	General warning sign

SYMBOL	MEANING
	Indicates that the product can only be used indoors
	Indicates that the product can only be operated by direct current from the battery supplied
	Warning: crushing hazard
	CE marking – symbol indicates compliance with Machinery Directive 2006/42/EC and the Regulation on medical devices 2017/745/
	Indicates permissible minimum and maximum relative humidity levels during use
	Protect from rain
	Indicates minimum and maximum temperatures to which the product can be safely exposed
	Indicates permissible minimum and maximum atmospheric pressure during transport and storage
	This way up
	Do not open with a sharp blade
	Do not sit
	Service label

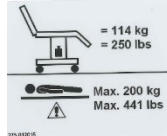
SYMBOL	MEANING
	Applied part type B, in accordance with IEC 60601-1
	Disposal in the EU: do not dispose of with household waste
	Consult instructions for use.
S3 – 15% (1' 30" / 8' 30")	Specifying the nominal operating time S3 15% means that in any 10-minute period, the lifting column can only be operated for 1.5 minutes and must then cool down for the remaining 8.5 minutes.
	Indicates minimum and maximum temperatures to which the product can be safely exposed
	Protect from sunlight
	Indicates permissible minimum and maximum relative humidity levels during transport and storage
	Fragile: handle with care
	Do not stack
	Electric shock
	Do not load
	Weight label

2. REPORTING INCIDENTS

Any complaints about the product's safety, efficacy or performance must be reported to AKRUS (info@akrus.com) or to their local distributor. If necessary, the local competent authority must also be informed.

3. REQUIREMENTS FOR SAFE OPERATION

Please familiarise yourself with contents of this IFU before putting into service the device for the first time. Users require no training to operate the product.

	WARNING
	<p>Risk of death and injury due to defective product.</p> <ul style="list-style-type: none"> ▪ Please check that the product is working correctly before every use. ▪ A defective product must not be used.

	WARNING
	<p>Risk of injury due to use in an unsuitable environment.</p> <ul style="list-style-type: none"> ▪ The product must not be used in potentially explosive atmospheres. ▪ The product must not be used or stored in damp rooms, and under no circumstances in rooms with dripping, splashing or spraying water. ▪ The product must not be used with volatile anaesthetics or volatile anaesthetics with oxidants. ▪ This product must only be operated in compliance with the specifications for intended use and the environmental conditions described in Section 18.

	WARNING
	<p>Risk of injury due to unauthorised modifications to the product.</p> <ul style="list-style-type: none"> ▪ Unauthorised modification of the product is prohibited. ▪ Modifications authorised by the manufacturer may only be carried out by personnel authorised by the manufacturer. ▪ Servicing and repairs to this product may only be carried out by personnel authorised by the manufacturer. ▪ Please also refer to the national qualification guidelines which apply in your country.

	WARNING
	<p>Risk of death and injury due to improper patient positioning</p> <ul style="list-style-type: none"> ▪ Only place patients in the positions intended to be used with the product and do not leave patients unattended. ▪ Fasten the patient with a suitable accessory if necessary. ▪ Never change the settings of the product during an active surgical procedure. ▪ Comply with the weight restrictions specified by the manufacturer. Never exceed the specified weight limit of the chair.

	CAUTION
	<p>The surgical chair can move away on its own</p> <ul style="list-style-type: none"> ▪ Always lock the foot brake except during transportation. ▪ Always check the position of the foot brake before moving the patient.

	IMPORTANT
	<p>Damage to the equipment due to incorrect handling.</p> <ul style="list-style-type: none"> ▪ When cleaning, make sure that no water or liquid enters the electrical or electronic components. ▪ The product must not be used as a holder for surgical equipment (e.g. surgical instruments, clothing, IV bags or other items). ▪ Do not place any sharp or pointed objects on the product upholstery. ▪ Do not store or transport any objects or devices on the product.

4. PRODUCT SERVICE LIFE AND WARRANTY CONDITIONS

The expected lifetime of the product is **8 years**. Product lifetime and the manufacturer's warranty are subject to compliance with all conditions and regulations stated in these Instructions for use.

i	IMPORTANT
	<ul style="list-style-type: none"> ▪ In consideration of the potential associated risks, the medical device has been developed, produced and maintained with the assumption that the product will have a useful life of 8 years and be maintained at the prescribed intervals. ▪ Modifications to the product, or failure to comply with the manufacturer's specifications may significantly reduce the product's expected lifetime, or significantly increase the risks of using the product. ▪ It is the responsibility of the operator (institution) to follow the manufacturer's instructions and to assess the risk/benefit ratio taking into account the product lifetime that has elapsed or maintenance and inspection intervals in accordance with the manufacturer's instructions.

5. CONTENTS AT DELIVERY

The delivery of the SC 5010 HS / ES includes the following items:

ITEM	NUMBER
SC 5010 HS / ES	1
Keypad	1
Charging station and power cable	1
Battery	1
Quality test report	1
Instructions for use (IFU)	1

6. INTENDED USE

The SC 5010 HS / ES surgical chair is a medical device for use in human medicine. The surgical chair may only be operated by qualified personnel.

6.1. INTENDED PURPOSE AND INDICATIONS

The mobile, electrically operated SC 5010 HS / ES surgical chair is designed for placement and positioning of patients in the required posture during diagnostic and therapeutic procedures as well as during surgical interventions on humans. The product enables optimal access to the patient's head in its various positions and is intended for use in the following medical fields:

- Ophthalmology
- ENT (ear, nose and throat)
- Oral and maxillofacial surgery
- Plastic, reconstructive and aesthetic surgery, primarily in the head area
- Dentistry
- Dermatology
- Nerve stimulation
- Blood donation

Due to its design, functionality and accessories, the surgical chair only allows the following positioning of patients:

- Supine position
- Sitting position
- Beach chair position
- Prone position
- Shock position: Zero position and Trendelenburg position.

The surgical chair is designed for patients weighing a maximum of 200 kg. The headrest is designed to support a maximum weight of 20 kg.

The surgical chair is only intended for positioning patients immediately before, during and after a procedure/surgical intervention and for short-distance transportation for transfer purposes. Positioning may only be carried out by appropriately trained specialist personnel.

The product is suitable for use in the immediate controlled patient environment.

6.2. CONTRAINDICATIONS AND ADVERSE EFFECTS

The surgical chair must **not** be used:

- for patients weighing > 200 kg
- for neurosurgical procedures or for medical fields and procedures not listed above
- to place patients in positions for which the surgical chair is not intended
- for prolonged patient transport
- with or in the same room as an X-ray machine or MRI machine
- with a third-party accessory that could affect the safety of patients

The product has **no** known adverse effects.

Any use other than the stated intended purpose is prohibited.

7. PUTTING INTO SERVICE



IMPORTANT

The product may only be opened by persons authorised by the manufacturer.



The product is supplied in non-sterile condition.

Before using the product for the first time, it must be prepared as described in Section 12.

	<p>The product and battery are delivered in separate packaging.</p> <p>Before using the device for the first time, the battery must be inserted as described in Section 10.4.</p>
---	---

No further assembly or calibration is required to operate this medical device.

8. ELECTRICAL CONNECTIONS

	<p>WARNING</p> <p>Risk of death due to electric shock.</p> <ul style="list-style-type: none"> ▪ The medical device is only free from electric current when the battery is disconnected. ▪ The exact position of the battery or the charging station is described in the relevant sections of this IFU (see Section 10.4). ▪ Only the power cable supplied or specified by the manufacturer can be used to connect the charging station to mains electricity. ▪ Only use the battery and charging station when they are in good condition.
---	---

9. ACCESSORIES

The SC 5010 HS / ES surgical chair is equipped with rails along the backrest and lying surface for attaching accessories such as infusion stands, anaesthesia screens, etc. To attach these accessories, check that the clamp is secure.

ACCESSORIES	NAME	AKRUS ITEM NO.
	<p>Foot-controlled switch</p>	<p>275.012400</p>
	<p>Foot joystick</p>	<p>275.012500</p>
	<p>Max. 20 kg Ankylosing spondylitis extension</p>	<p>240.030670</p>

ACCESSORIES	NAME	AKRUS ITEM NO.
	<p>Multi-articulated armrest (max. 10 kg) <i>Please ensure that the front edges of the armrests cannot come into contact with the rail of the seat when the backrest is upright</i></p>	241.030250
	<p>IV stands</p>	240.030501
	<p>Anaesthesia screen, rigid, stainless steel</p>	240.030500
	<p>Safety rail</p>	240.020200

10. DEVICE DESCRIPTION AND OPERATING CONTROLS

10.1. KEYPAD CONTROLS (101-152)

The keypad is connected to the control unit under the cover on the lower frame with a spiral cable. The keypad can be hung in any position using the hook on the back. Always ensure that the spiral cable cannot be crushed between or cut off by moving parts of the chair.

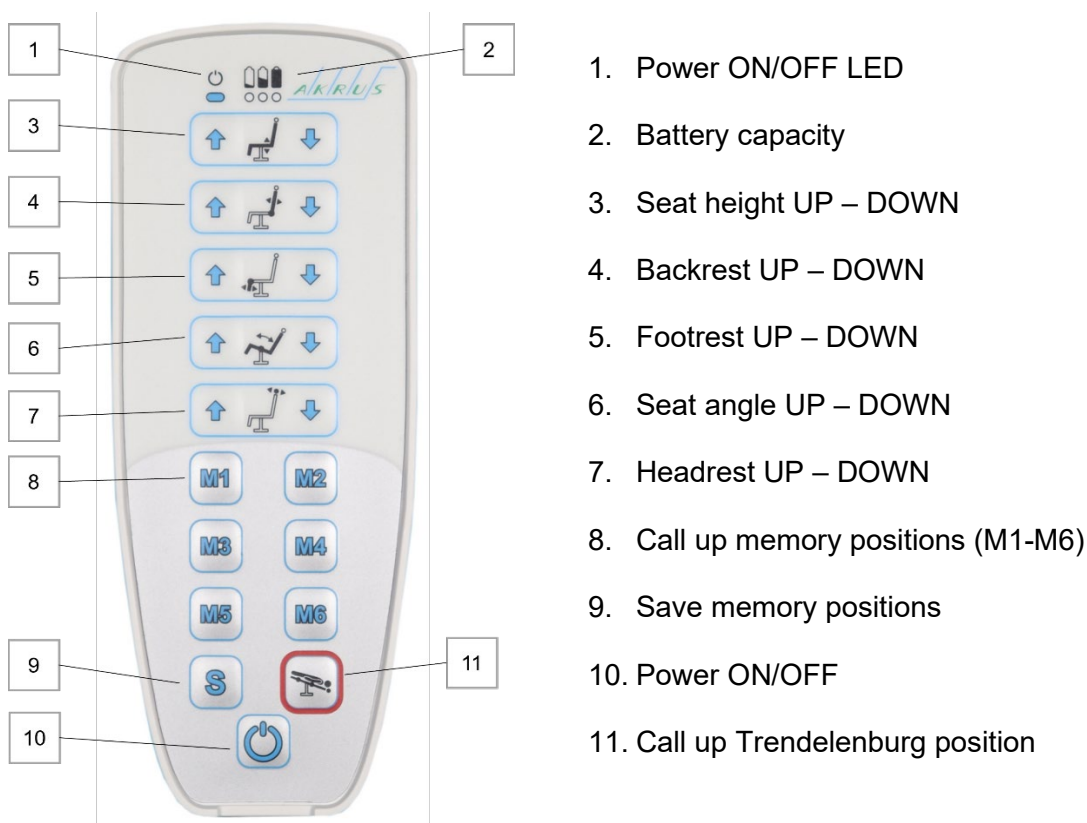

10.2. BATTERY (100-925)

All electric motors of the SC 5010 HS / ES are powered by a rechargeable battery. The battery has a capacity of approx. 40 operations per charging cycle when used with a typical load profile.

	CAUTION
	<p>The battery must be charged regularly.</p> <ul style="list-style-type: none"> ▪ Keeping a spare, charged battery is recommended.

	IMPORTANT
	<p>Please handle the battery with care and caution. Incorrect handling, as described below, can significantly damage or even destroy the battery:</p> <ul style="list-style-type: none"> ▪ Total discharge ▪ Drops (even from low heights)

- Short-circuiting the terminals

	IMPORTANT
	<p>In the cases below, the battery may be faulty if the ON LED is lit and:</p> <ul style="list-style-type: none"> ▪ the CHARGE LED does not come on ▪ the CHARGE LED flickers ▪ the battery is empty soon after charging ▪ the battery is not fully charged after even a long charging time (> 4h). <p>If any of the above occur, please replace the old battery with a new battery. Please contact your local AKRUS authorised distributor.</p>

	<p>The battery should be charged approximately every 3 days by the user or maintenance staff, or daily if used intensively (> 30 uses/day). It can be charged overnight or at weekends: the battery cannot be damaged by over-charging, so does not need to be removed from the charging unit once fully charged.</p>
---	--

10.3. BATTERY CHARGING STATION (100-924)



Fig. 1 Charging station with power cable

The charging station can detect the power supply level. It is suitable for voltages from 110 volts to 240 volts at 50/60 Hz.



Fig. 2 Indicator light ON and CHARGING

A green LED indicates it is ready to charge.

Charging can take up to 4 hours, and is indicated by a yellow LED. When charging is complete, this LED turns off.



The charging station is wall-mounted with 2 screws. It is important to mount the charging station vertically, so that gravity holds the battery contacts securely onto the terminals on the charger.

Fig. 3 Vertical configuration of the charging station

10.4. BATTERY HOLDER ON THE SB 5010 HS / ES SURGICAL CHAIR



The battery holder is easily accessible under the seat.

There is a recessed handle on the top of the battery. To remove the battery from the holder, gently pull on the recessed handle. To insert the battery, push it gently into the holder until you hear a click. It is now locked into place.

Fig. 4 Location of the battery holder

10.5. ELECTRIC DRIVES AND CONTROL UNIT

The SC 5010 HS / ES chair is powered by low voltage motors. The control unit is located in the seat frame under the seat cushion.

10.6. OPERATING CONTROLS - FOOT-CONTROLLED SWITCH (275.012400 OPTIONAL)

The foot-controlled switch is firmly attached to the chair with a retaining plate. However, it can be removed from the retaining plate so that it can be placed on the floor as required.



1. Backrest UP
2. Backrest DOWN
3. Bed height UP
4. Bed height DOWN

Fig. 5 Foot-controlled switch

10.7. OPERATING CONTROLS - FOOT JOYSTICK (649.012020 OPTIONAL)

The foot joystick is fixed and should be operated with the feet.

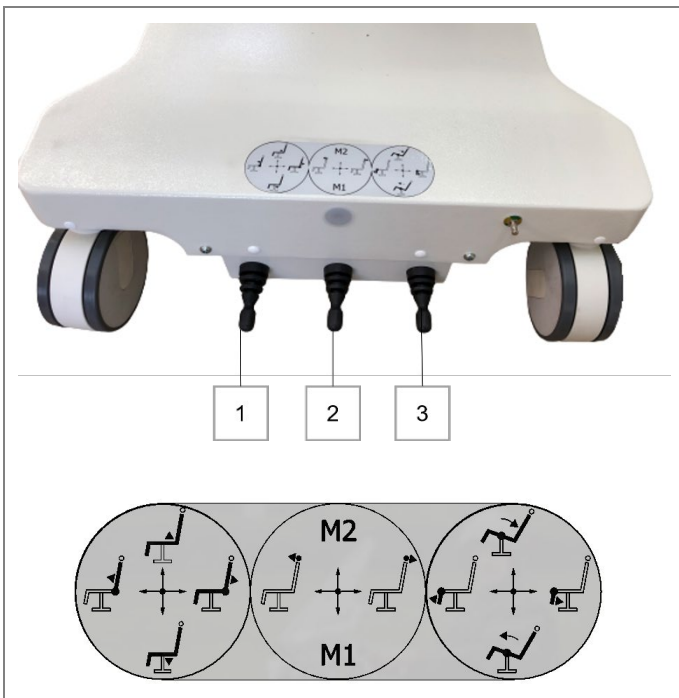

1. Back UP / DOWN (left, right)
Seat height UP / DOWN (up, down)
2. Headrest UP / DOWN (up, down)
3. Lying position UP / DOWN (up, down) / Footrest UP / DOWN (left, right)

Fig. 6 Foot joystick

10.8. WHEEL BASE LEVER



The surgical chair has 4 smooth-running castors. The castors can be locked in three positions using the central foot lever.

Fig. 7 Position of the foot lever on the surgical chair

The following positions are available:

- All wheels move freely and rotate
- All wheels move freely, and 1 wheel is locked for steering
- All wheels are braked



Fig. 8 Foot lever position "All wheels braked"



Fig. 9 Foot lever position "All wheels free"



Fig. 10 Foot lever position "One wheel locked for steering"

To operate the foot lever correctly, position your foot parallel to the base and push down firmly on the lever with your toes (see **Fig. 11**). It is incorrect to place the foot in the middle of the axle, or perpendicular to the lever from the side, as this makes it difficult to exert force on the lever (see **Fig. 12** and **Fig. 13**).



Fig. 11 Correct operation



Fig. 12 Incorrect operation

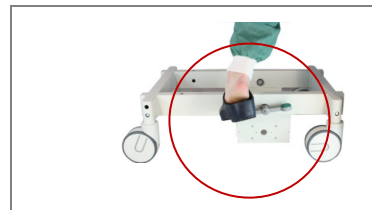

Fig. 13 Incorrect vertical operation

11. OPERATING THE SURGICAL CHAIR

For the purposes of single fault safety, we offer a replacement battery to enable the shock positions (Trendelenburg position and zero position) to be reached.

11.1. CONTINUOUS OPERATION OF THE MOTORS

i	IMPORTANT
<p>The electric motors are designed for brief operation for a maximum of 6 minutes. A longer operating time can cause overheating and permanent damage to the transformer.</p>	

11.2. AUDIBLE SIGNAL, BATTERY CHARGE STATUS

A beep sounds when the battery reaches 80% discharge while the motors are running. The battery must then be recharged in the charging station. Continued operation can damage the battery if it is completely discharged.

The hand control also has a battery capacity indicator:



Battery status:

- Low battery status (red LED) >> 25%
- Medium battery status (yellow LED) >> 50%
- Full battery status (green LED) >> 100%

Fig. 14 Battery status indicator

11.3. POWER BUTTON (ON/OFF BUTTON)

The surgical chair has an automatic energy-saving mode. The hand control locks itself after 2 minutes. The system switches back on automatically. As soon as an axle is activated, the chair is ready for operation again after 0.5 seconds. It is also possible to switch the application off completely by pressing the power button for 2 seconds. In this state, no motor can move even if an axle is inadvertently activated.

The backlight of the hand control switches off automatically after 50 seconds.

11.4. ELECTRICAL ADJUSTMENT OPTIONS

The height, backrest, footrest, seat and headrest can be adjusted electrically by pressing the relevant button.

11.4.1. ADJUSTING THE HEIGHT

By pressing the height adjustment button, the chair can be continuously adjusted between minimum and maximum height.



Fig. 15 Maximum height of the surgical chair



Fig. 16 Minimum height of the surgical chair

11.4.2. BACKREST ADJUSTMENT

The backrest can be continuously adjusted from vertical to horizontal position by pressing the corresponding button.



Fig. 17 Vertical backrest position



Fig. 18 Horizontal backrest position

11.4.3. ADJUSTMENT OF THE FOOTREST

The footrest can be moved to the desired position by pressing the corresponding buttons on the keypad.



Fig. 19 Vertical footrest position



Fig. 20 Horizontal seat position

11.4.4. ADJUSTING THE SEAT

The seat can be moved to the desired position by pressing the corresponding buttons on the keypad.



Fig. 21 Vertical seat position



Fig. 22 Horizontal seat position

11.4.5. ADJUSTMENT OF ELECTRIC HEAD LIFTER



Fig. 23 Positioning the headrest



11.4.6. TRENDLENBURG POSITION

The Trendelenburg position is set either by pressing the individual buttons for the seat and backrest or by pressing the button outlined in red. The shock position is already saved and can be called up here.

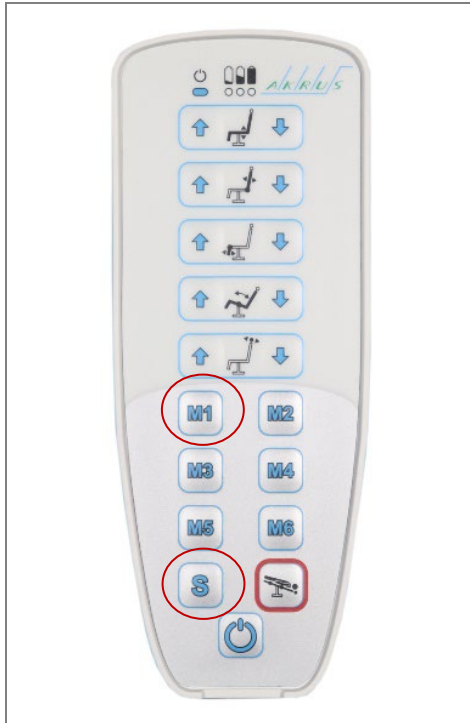

Fig. 24 Trendelenburg position of the surgical chair



11.4.7. PROGRAMMING THE MEMORY BUTTONS (101-152)

To save a position, please proceed as follows:



1. Place the chair, including the headrest, in the desired position using the operating buttons.
2. Briefly press and release the "S" button at the bottom left - you should hear a triple beep.
3. Now hold down one of the memory buttons (**M1-M6**) to save this position for the duration of the beep (2 seconds).
4. A short continuous beep confirms that the position has been saved.
5. To call up the memorised positions, press and hold the desired memory button until the saved position is reached.

For safety and regulatory reasons, the buttons (M1 - M6) must be held down while the bed is in motion.

Fig. 25 Position of the memory buttons

11.5. ADJUSTING THE HEADREST

Various headrests are available for the SC 5010 HS / ES . With a universal adapter, all headrests can be replaced in just a few seconds without tools.

11.5.1. ADJUSTING THE STANDARD HEADREST (241.030690)

Both the length extension and the self-levelling tilt angle of the headrest (max. 20 kg) can be adjusted with a central locking mechanism.

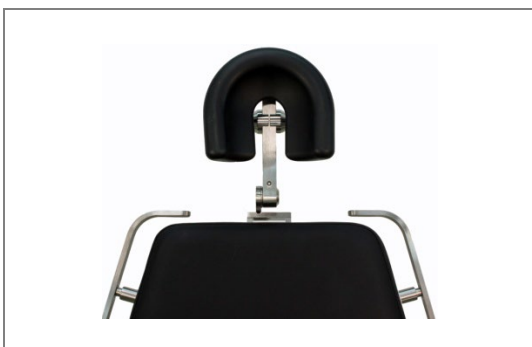

Fig. 26 Horizontal seat position

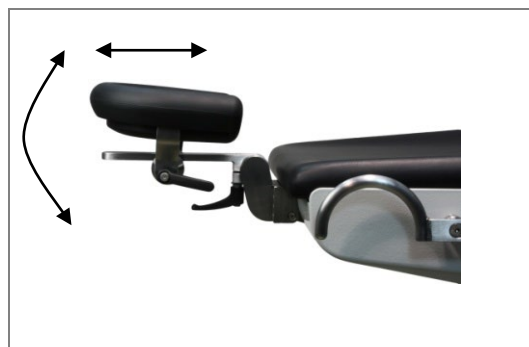

Fig. 27 Tilted seat position

11.5.2. ADJUSTMENT OF THE PADDED HEADREST (241.030660)

The padded headrest (max. 20 kg) can be adjusted lengthwise with a tommy screw.



Fig. 28 Horizontal seat position

11.5.3. ADJUSTING THE MULTI-ARTICULATED HEADREST (241.030648)

This optional headrest (max. 20 kg) can be adjusted very precisely and individually to the patient via several joints. It can be moved approx. 10 cm away from the back section using mechanical clamp fasteners and tilted by +20° and - 20°.

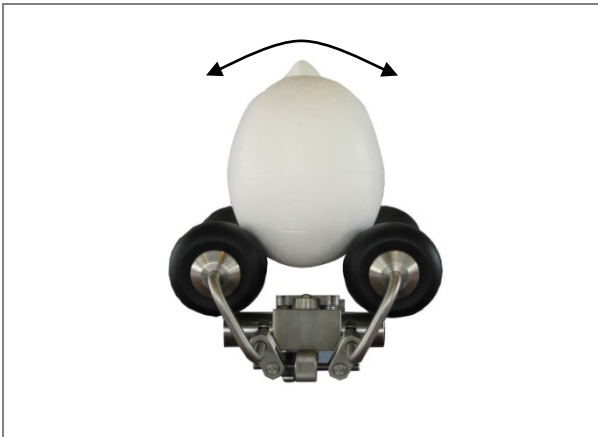

Fig. 29 Positioning the head on the support

The head is always optimally supported thanks to the two-point mounting. The visco-elastic padding can be adjusted in width using an adjusting screw and thus individually adapted to any head size.

By briefly opening the locking screw, the headrest automatically falls into a comfortable position for the patient.

The headrest is also suitable for lateral head support without the need to replace accessories.



Fig. 30 Max. retracted head support



Fig. 31 Max. extended head support

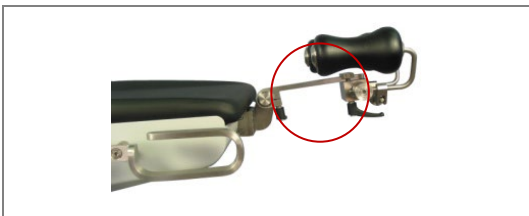

Fig. 32 Tilt angle -20°

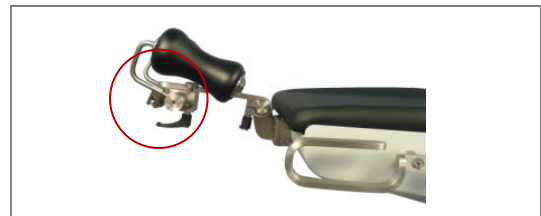

Fig. 33 Tilt angle $+20^{\circ}$

11.5.3.1. MANUAL ADJUSTMENT OF TILT ANGLE (275.030650)

For certain applications that require extreme ventral and dorsal tilt angles, an optional adjustment device 275.030650 (max. 20 kg) with an additional clamping lock is used. This clamp fastener is located under the headboard.



Fig. 34 Tilt angle $+40^{\circ}$ and position of the clamping lock for tilting mechanism.



Fig. 35 Tilt angle -50°

12. DEVICE CARE AND REPROCESSING

The product is a **reusable** medical device. Repeated reprocessing of these products usually has little effect. The service life of the product is generally determined by normal wear and tear and damage caused by use.

The product should be cleaned and disinfected after each use. National legal regulations, national and international standards and guidelines, and the institution's own hygiene regulations for reprocessing must be complied with.

The product can be disinfected by wiping it and is considered a safe medical device for which no special reprocessing requirements apply.

12.1. GENERAL INFORMATION

	WARNING
	<p>Risk of infection due to incorrect cleaning and disinfection</p> <ul style="list-style-type: none"> ▪ Please follow the processing instructions to avoid the risk of contamination. ▪ Device maintenance and reprocessing should only be carried out by suitably qualified personnel. ▪ Always wear gloves and suitable work clothing when cleaning and reprocessing.

	WARNING
	<p>Risk of infection due to incomplete cleaning</p> <ul style="list-style-type: none"> ▪ Heavy soiling can cause dirt residues to remain on the appliance surfaces, which can mean disinfection is not complete. ▪ A weak alkaline cleaner can be used to remove heavy soiling. Apply to a damp cloth only; do not use too much water.

	WARNING
	<p>Risk of infection due to the use of incorrect care products</p> <ul style="list-style-type: none"> ▪ Preparation is based on a validated procedure. ▪ Cleaning and disinfection should only be done using ready-to-use "Cleanisept Wipes Maxi" from the manufacturer Dr. Schumacher GmbH. ▪ It is essential that only the cleaning and disinfection methods recommended in the user manual be used. Any deviations from this require prior consultation with an authorised service technician to ensure that the proposed methods do not cause damage to the product.

	WARNING
---	----------------

	<p>Electric shock due to contact of the battery with moisture.</p> <ul style="list-style-type: none"> ▪ The battery must be removed before the chair is cleaned. The chair must be completely dry before the battery is reinserted. ▪ The battery itself should only be cleaned with slightly damp cloths in exceptional cases and should only be reinserted in the device once it is completely dry.
--	--

	<p>CAUTION</p>
	<p>Risk of injury due to the use of improper cleaning agents and disinfectants</p> <ul style="list-style-type: none"> ▪ Mixing different chemical substances in cleaning agents and disinfectants can lead to undesirable chemical reactions. ▪ Comply with the processing instructions and use only specified agents. ▪ Between cleaning steps, wipe the appliance thoroughly with clean water and a slightly damp cloth.

	<p>IMPORTANT</p>
	<p>Damage to the product due to unsuitable cleaning and disinfection</p> <ul style="list-style-type: none"> ▪ It is strictly forbidden to clean the product or its accessories in autoclaves, sterilisers, automatic machine cleaners or other high-temperature systems, as such a procedure could damage the product. ▪ Do not carry out any other mechanical cleaning (including high-pressure cleaners). ▪ Do not apply water, cleaning agents or disinfectants directly to joints, seams or gaps in the upholstery or to connecting parts/joints. ▪ Penetration of the liquid into the interior of the appliance can damage it. There is a risk of corrosion. ▪ If the pad is damaged, do not use the appliance until the pad has been replaced. ▪ If there is too much liquid in the joints, seams, gaps or other parts of the appliance, wipe them off thoroughly with a lint-free dry cloth. <p>Do not use any substances that contain abrasives, alcohol, halides, acids, iron particles or solvents.</p>

12.2. REPROCESSING INSTRUCTIONS

12.2.1. CLEANING PROCEDURE



<p>Preparations before cleaning</p>	<p>Remove the battery from the medical device. Remove detachable accessories from the product before cleaning.</p>
<p>Cleaning</p>	<p>For manual cleaning, use ready-to-use “Cleanisept Wipes Maxi” by</p>

	<p>manufacturer Dr. Schumacher GmbH. Please proceed as follows:</p> <ul style="list-style-type: none"> ▪ Follow the instructions from manufacturer Dr. Schumacher on using personal protective equipment. ▪ Clean visibly contaminated surfaces with a CLEANISEPT WIPE and remove contamination. Dispose of used wipes. ▪ Wipe surfaces with CLEANISEPT WIPES until fully wetted. Allow to dry for the full contact time. Dispose of used wipes. ▪ According to VAH, the full contact time is 1 minute. ▪ Discard the used wipe and begin disinfection.
Drying	<p>Cleaning with "Cleanisept Wipes Maxi" from the manufacturer Dr. Schumacher GmbH does not require any extra drying time before subsequent disinfection with the same "Cleanisept Wipes Maxi" from the manufacturer Dr. Schumacher GmbH is carried out.</p>
	<p>When using other care products, it is essential to wipe with clean water and allow the product to dry completely.</p>

12.2.2. DISINFECTION PROCEDURE

Preparations before disinfection	<p>Ensure that the device can be disinfected with "Cleanisept Wipes Maxi" from the manufacturer Dr. Schumacher GmbH and that no dirt residue remains on the device.</p>
Disinfection	<p>For manual disinfection with wipes, use ready-to-use "Cleanisept Wipes Maxi" by manufacturer Dr. Schumacher GmbH. Please proceed as follows:</p> <ul style="list-style-type: none"> ▪ Follow the instructions from manufacturer Dr. Schumacher on using personal protective equipment. ▪ To disinfect surfaces, wipe with CLEANISEPT WIPES until fully wetted. Allow to dry for the full contact time. ▪ According to VAH, the full contact time is 1 minute.
Drying	<p>Allow the device and accessories to dry.</p>
	<p>If the product or its accessories come into direct contact with the skin (without a surface in between), wipe off the disinfectant residue with clean water in accordance with the manufacturer's instructions.</p>

12.2.3. COMPLETION OF PROCESSING

	<p>Allow the chair to dry completely before use. Pay particular attention to drying areas that are difficult to access.</p>
	<p>Do not replace the battery until the chair is completely dry!</p>

Maintenance and checks before use	No maintenance is required. The product is maintenance free. See Section 14. After each cleaning, carry out a visual and functional inspection as described in Section 13.
Packaging	No final packaging is provided for the product. It is recommended to protect the device with a dust cover/drape between uses.
Storage	The product should always be stored in a clean, cool and dry place, protected from mechanical damage and handled with care. The accessories should be stored away from dust. Do not drop the accessories.

13. CHECKS BEFORE USE

	WARNING
	<p>Risk of death and injury due to defective product.</p> <ul style="list-style-type: none"> ▪ A visual and functional inspection of the product must be carried out before each use. ▪ Particular attention must be paid to ensuring that the accessories are adequately secured and stable. ▪ If any wear and tear is visible on the medical device, it must be repaired before use. See Section 14.

14. DEVICE MAINTENANCE AND REPAIR

The product does not need to be maintained by the user.

The product is subject to the regular service intervals specified in the current product service report sheet.

It is prohibited to use a defective product or to carry out repairs yourself.

If device defects occur, please have the following information ready for AKRUS or the responsible distributor:

- Description of the defect
- Product number (see nameplate)
- If available: Serial number (see nameplate)
- Year of manufacture (see nameplate)

The following table contains a list of spare parts that are approved for use with the position surface or surgical bed.

DESCRIPTION	AKRUS ITEM NO.
Bed castor	320-198
Bed castor, antistatic	320-112

DESCRIPTION	AKRUS ITEM NO.
Bed castor, antistatic, with directional lock	320-197
Electronic control unit	275.999005
Electronic control unit (heavy duty)	275.999009
Replacement battery	100-925
Foot joystick, 5 functions (SC 5010 HS/ES)	275.012500
Foot-controlled switch chair up/down and backrest up/down	275.012400
Support bracket for standard headrest	241.030 651
Support bracket for additional tilt	241.030 650
Hand control, 6 functions, 2x memory (standard)	101-151
Head cushion section for 241.030648	200-511
Head cushion section for 241.030690	200-512
Headrest w. recessed padding	241.030690
Charger	100-924
Back padding	275.930000
Back padding (viscoelastic)	275.930100
Seat cushion	275.920000
Seat cushion (viscoelastic)	275.920100
Power supply	100-898
Adjustment drive (footrest adjustment)	101-082
Adjustment drive (headrest adjustment)	101-095
Adjustment drive (backrest adjustment)	101-082
Calf pad for SC 5010 ES only	242.950000
Calf pad for SC 5010 ES only (viscoelastic)	242.950100
Calf pad for SC 5010 HS only	275.950000
Calf pad for SC 5010 HS only (viscoelastic)	275.950100

15. SAFETY INSPECTIONS

A safety check of the bed is NOT prescribed by the manufacturer; however, the operator must observe any deviations from this in accordance with national regulations for Class I medical devices in their currently valid version.

16. DISPOSAL

	WARNING
	<p>Risk of infection.</p> <ul style="list-style-type: none"> ▪ Used products or parts thereof may be contaminated. ▪ Before disposing of the product, it must be reprocessed in accordance with

	Section 12.
--	-------------

The basis for disposing of waste in the European Union is the European Waste List. In some cases, countries and even municipalities issue their own waste regulations, which must be complied with. Outside the European Union, the relevant country-specific regulations for waste disposal must be complied with.



The battery and all electrical components (motors, control unit) must be disposed of properly as electronic waste or returned to the distributor. This product falls within the scope of Directive 2012/19/EU (Waste Electrical and Electronic Equipment Directive). The product is not registered for use in private households; disposal via municipal collection points for old electrical appliances is not permitted.

All other components are household waste.

17. TECHNICAL DATA

The device fulfils the requirements of IEC 60601-1-2/EN 60601-1-2 "Electromagnetic compatibility - Medical electrical equipment" without deviation or restriction.

Technische Daten	Technical Data	Value	Unit
Maße und Gewicht	Dimensions and weight		
Gesamtlänge Fahrwerk (R-Lehne senkrecht)	Wheel base length (backrest vertical)	760	mm
Gesamtbreite Fahrwerk	Wheel base width	580	mm
Gesamtbreite Stuhl mit Geräteschiene	Chair width incl. attachment rails	700	mm
Breite Sitzfläche	Chair cushion width	590	mm
Tiefe Sitzfläche	Chair cushion depth	450	mm
SC 5010 ES (eye surgery)			
max. Länge Rückenlehne waagrecht	Max. chair length, back rest horizontal	2050	mm
SC 5010 HS (head surgery)			
max. Länge Rückenlehne waagrecht	Max. chair length, back rest horizontal	2050	mm
Patientengewicht maximal	Max. patient weight	200/300	kg
Masse (abhängig von Optionen) ca.	Bed weight (depending on options) approx.	114	kg
Verstellbereich Liege vertikal (Z)	Vertical bed range (Z axis)		
SC 5010 ES (eye surgery)			
Einstieghöhe Liegenpolster min	Lowest entry height	520	mm
Hub	Lift	260	mm
SC 5010 HS (head surgery)			
Einstieghöhe Liegenpolster min	Lowest entry height	610	mm
Hub	Lift	350	mm
Verstellbereich Rückenlehne	Back rest range		
Waagrecht bis Senkrecht	Horizontal to vertical	0-85	°
Schocklagerung unter waagrecht	Shock position below horizontal	-20	°
Fahrwerk	Wheel base		
3 Pos. Bremssystem <ul style="list-style-type: none"> • alle Räder frei • 1 Lenkrolle fixiert • alle Räder verriegelt 	3 brake system options <ul style="list-style-type: none"> • all wheels pivoting • 1 wheel locked for steering • all wheels locked 		
Rollendurchmesser	Wheel diameter	125	mm
Elektrische Angaben	Electrical data		
Battery	Battery	24 (2.9)	Volt (Ah)
Mains electricity (charging station)	Power cable for recharging	100-240	Volt
Charging time approx.	Recharging time required	4	h
Nominal frequency	Nominal frequency	50 – 60	Hz
Nominal current	Nominal power	400	mA
Schutzart	Protection category	IP 65	
Dauer Kurzzeitbetrieb Motoren (ID 10)	Continuous operation of electric motors	6	minutes
Electrical safety class		I	
Emissions class		A	
Group (RF emission according to CISPR 11)		1	

18. ENVIRONMENTAL CONDITIONS

ENVIRONMENTAL CONDITIONS FOR INTENDED USE	
Air temperature	+10°C to +40°C
Rel. max. humidity	50% non-condensing
Air pressure	700 – 1060 hPa
ENVIRONMENTAL CONDITIONS FOR STORAGE	
Air temperature	-10°C to +55°C
Rel. humidity	10% to 95% non-condensing
ENVIRONMENTAL CONDITIONS FOR STORAGE AND TRANSPORT IN ORIGINAL PACKAGING	
Air temperature	-40°C to +70°C
Rel. humidity	10% to 95% non-condensing

19. TROUBLESHOOTING

FAULT	POSSIBLE CAUSE	CORRECTIVE ACTION
Does not work at all	Battery empty	Charge battery
	Battery seated incorrectly	Check battery seat (see also Section 10.4)
	Keypad cable not plugged in correctly	Check keypad cable (see also Section 10.1)
Does not work at all, charge battery	Battery faulty	Call customer service
Individual functions not working.	Cable connection of the motors to the control unit not correct	Check cable connection (see also Section 10.1)
“ON” LED on charging unit does not come on	Power cable not plugged in	Check power cable (see also Section 10.3)
	Charging unit faulty	Call customer service
Charging LED on charging unit does not come on	Charging unit faulty	Call customer service
Mechanical damage	External causes	Call customer service

